

EBH18A - bush replacement tool kit for heavy road vehicles

For powerful and versatile performance

The EBH18A universal hydraulic bushing replacement tool kit is used for a wide variety of applications on truck and bus workshops worldwide. It will fit brands like Scania, Volvo, MAN, Mercedes, Renault, Iveco and DAF.

Working with EBH18A to replace bushings, axles and bearings is easy and saves time. Once you have become familiar with the system and how to use it, you will find it very easy to adapt it to many other applications where performing difficult operations in less time is important. A 50% or more time saving is not unusual!

EBH18A does the job on the spot

In many cases the amount of strip-down preparation is reduced and the need to take the part to a workshop press eliminated. Instead you can work with the Universal hydraulic tool kit directly on the vehicle.

Free hands for higher precision

When the kit is assembled for a particular task it can be set in position with high precision by means of the air/hydraulic foot pump, which leaves you with two hands free at all times.

No damage to the vehicle parts

The traditional way of working using a slide-hammer or other lumbering tools can damage vehicle parts. This is in most cases avoided by using the EBH18A kit.

Environmentally friendly and appreciated

Now when heating and hammering can be avoided, both service technicians and customers will appreciate the EBH18A HGV bushing tool kit.

The technician will be spared the noisy, potentially dangerous and physically straining working methods to replace bushings and can in a more up-to-date, ergonomically correct way and with less noise carry out his daily work. The vehicle owner will appreciate the low stand-still time which otherwise is time consuming and quickly return onto the roads.

The EBH18A kit can easily be equipped for different types of jobs

The available standard EBH18A kit will have a suitable fit for most applications. However, in some cases you need to adjust the tube adapter or bush removers to be able to carry out the job perfectly. In many cases these accessories are already available as standard.





Technical data

Technical data

Accessories

EB18-DAF

EB18-DAF accessory kit is intended to be used on DAF trucks with compressible bushings. It consists of one adapter sleeve and 3 press plates.

ETS18

The ETS18 accessory kit is intended to be used for compressible bushings and consist 5 different tapered support sleeves and 3 press plates. It fits Iveco, MAN and Mercedes commercial vehicles. Parts can be sold separately.

Name	Capacity kN (t)	Cylinder
EBH18A	176 (18)	CHFA182A

Table of content

Name	Description	Technical data
CHFA182A	Hollow cylinder with quick coupling	18t
AD6-18	Adapter	-
BR35-16	Press plate	ø 35 mm / Ø 16 mm
BR45-16	Press plate	ø 45 mm / Ø 16 mm
BR45/35-24	Press plate	Ø 45 mm / Ø 24 mm
BR55-20	Press plate	Ø 55 mm / Ø 20 mm
BR65-20	Press plate	Ø 65 mm / Ø 20 mm
BR65/45-30	Press plate	Ø 65 mm / Ø 30 mm
BR70-24	Press plate	Ø 70 mm / Ø 24 mm
BR90-73	Pull ring	Ø 90 mm
TA49	Sleeve	Ø 49 mm
TA73	Sleeve	Ø 73 mm
TR16-500	Threaded rod	M16 12.9, L: 500 mm
TR24-500	Threaded rod	M24 10.9, L: 500 mm
TR20-500	Threaded rod	M20 10.9, L: 500 mm

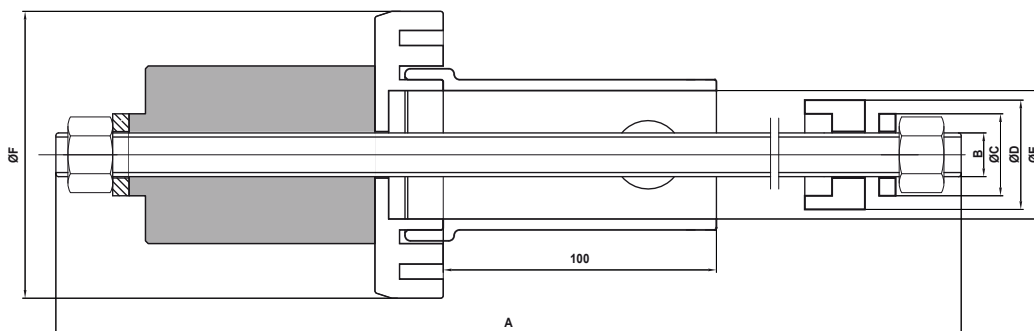

Name	A mm	B	C ø mm	D ø mm	E ø mm	F ø mm
EBH18A	500	M24	44	35 mm - 90 mm	49 mm, 73 mm	105



www.nikehydraulics.com

NIKE HYDRAULICS AB
 Box 1107
 631 80 Eskilstuna
 SWEDEN
 Tel +46 16 - 16 82 00
 Fax +46 16 - 13 93 16
 info@nikehydraulics.se

NIKE HYDRAULICS Inc.
 3980 W. Albany, Unit #1
 MCHENRY, IL 60050
 USA
 Tel + 1 815 385 7777
 Fax + 1 815 385 7776
 info@nikehydraulics.com

NIKE POWER EQUIPMENT Ltd.
 Unit 6, Stechford Trading Estate
 Lyndon Road, Stechford
 BIRMINGHAM B33 8BU, UK
 Tel +44 121 789 77 07
 Fax +44 121 789 68 66
 info@nikehydraulics.co.uk